

VER 1.0

Technical Manual

DS-OLS8-FPD



Table of Contents

 [Click to return to table of contents](#)

- 1. Features3
- 2. Technical Parameters3
- 3. Schematic diagram and Interface Definition.....4
- 4. Power Supply.....7
 - 4.1 Voltage.....7
 - 4.2 Current.....7
 - 4.3 Regenerative Discharge.....7
- 5. Motor Connection.....8
- 6. Signal Input.....9
 - 6.1 Pulse Signal : STEP9
 - 6.2 Direction Signal : DIR.....9
 - 6.3 Offline Signal : FREE.....9
 - 6.4 Pulse / Direction Input Timing Chart.....10
- 7. Typical Signal Connection.....11
 - 7.1 Differential Connection.....11
 - 7.2 Common Anode Connection.....11
 - 7.3 Common Cathode.....12
- 8. Typical Connection of Signal Output.....13
 - 8.1 Relay Connection.....13
 - 8.2 Optocoupler Connection.....13
- 9. Wiring Requirements.....14
- 10. Installation Size (unit : mm).....15

1. Features



- Input power: DC 24V-72V
- Eight current options
- PWM constant current bipolar subdivision drive
- Sixteen subdivision options
- Single/double pulse selection
- Photoelectric isolation input function, 5-24VDC compatible input
- Motor short circuit protection function
- Trial run function
- Exquisite design, low noise and low vibration
- With offline function

2. Technical Parameters



Drive model		DS-OLS8-FPD
Adapted motor	Suitable for two-phase hybrid stepping motor, DS-OLS8-FPD maximum suitable 7.8A	
Power supply	24 - 72V DC	
Output current	DS-OLS8-FPD: 2.8A-7.8A/phase (peak value)	
Drive method	Full-bridge bipolar PWM drive	
input signal	Pulse signal	Optocoupler input voltage H = 3.5-26V, L = 0-0.8V On-current 6-15mA
	Offline signal	
	Direction signal	
Output signal	Alarm Output	Photoelectric isolation output, maximum withstand voltage 30VDC, maximum saturation current 50mA
Size	118 × 78 × 34mm	
Weight	About 300 g	
Use environment	Use occasion	Avoid dust, oil mist and corrosive gas
	Humidity	<85% RH, no condensation
	Temperature	0°C - +40°C
	Heat dissipation	Install in a ventilated environment

3. Schematic Diagram and Interface Definition

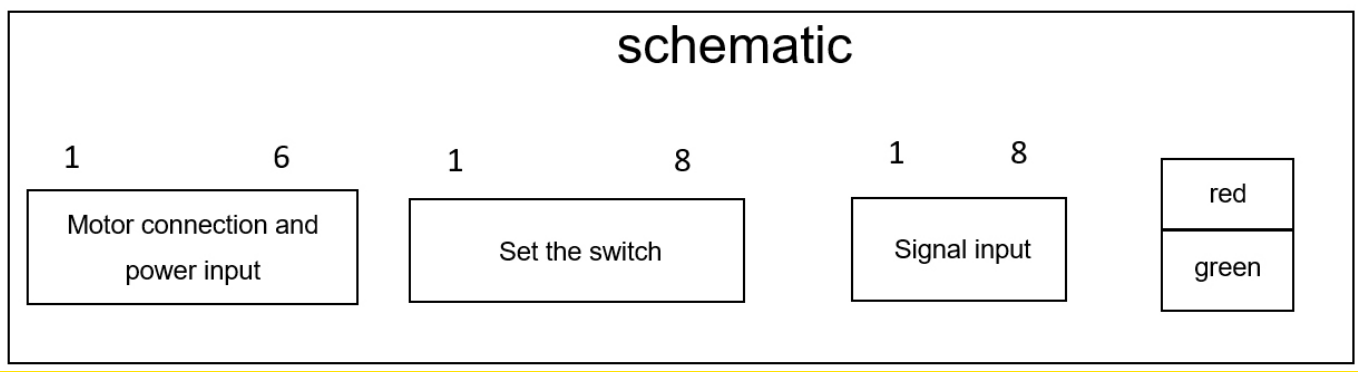
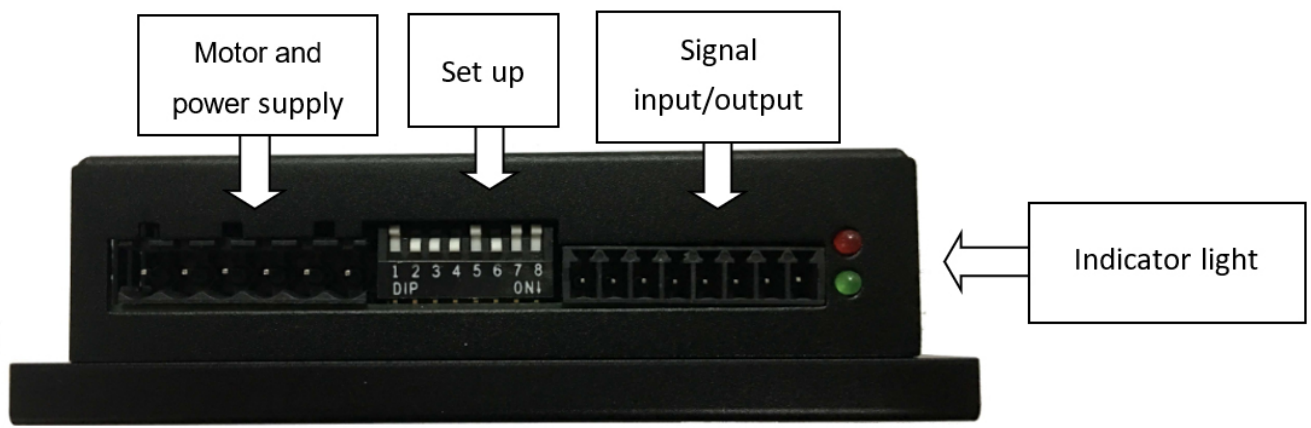

- 1. Signal input (according to the figure, arranged in order from left to right)**
 1 pin---pulse STEP+, 2 pin---pulse STEP-, 3 pin---direction DIR+, 4 pin---direction DIR-
 5 pin---offline FREE+, 6 pin---offline FREE-, 7 pin---output OUT+, 8-pin---output OUT-

- 2. Motor connection and power input (according to the figure, arranged in order from left to right)**
 1 pin---V+, 2 pin---V-, 3 pin---A+, 4 pin---A-, 5 pin---B+, 6 pin---B-

- **Set Switch**

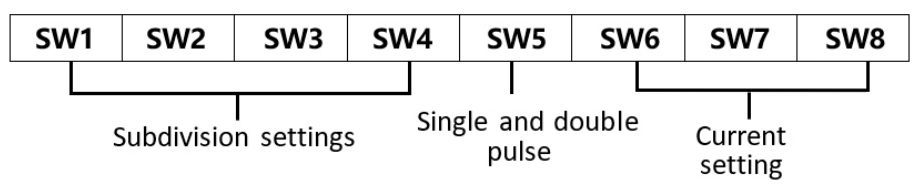

3. Subdivision Settings

DIP Switch				Number of Pulses/revolution
SW1	SW2	SW3	SW4	
ON	ON	ON	ON	400
ON	ON	ON	OFF	800
ON	ON	OFF	ON	1600
ON	ON	OFF	OFF	3200
ON	OFF	ON	ON	6400
ON	OFF	ON	OFF	12800
ON	OFF	OFF	ON	25600
ON	OFF	OFF	OFF	51200
OFF	ON	ON	ON	1000
OFF	ON	ON	OFF	2000
OFF	ON	OFF	ON	4000
OFF	ON	OFF	OFF	5000
OFF	OFF	ON	ON	8000
OFF	OFF	ON	OFF	10000
OFF	OFF	OFF	ON	20000
OFF	OFF	OFF	OFF	*Note



Notes

SW5-SW8 function multiplexing selection, please contact the manufacturer for specific content. Do not set SW1-SW4 , Set to all OFF state.

4. Current Setting

DIP switch			DS-OLS8-FPD Phase current (peak value)
SW6	SW7	SW8	
ON	ON	ON	2.8A
ON	ON	OFF	3.5A
ON	OFF	ON	4.2A
ON	OFF	OFF	4.9A
OFF	ON	ON	5.7A
OFF	ON	OFF	6.4A
OFF	OFF	ON	7.0A
OFF	OFF	OFF	7.8A

5. Operating Mode

SW5	Operation mode	Remarks
ON	Double pulse	
OFF	Pulse + direction	

Pulse + direction mode: pulse input is applied to the pulse input terminal, when the direction input terminal optocoupler fails, the motor rotates in one direction, and when the direction input terminal optocoupler is turned on, the motor rotates in the other direction;

Double pulse mode: when the pulse input terminal is pulsed, the motor rotates in one direction, and when the direction input terminal is pulsed, the motor rotates in the other direction.

Reuse self-check function

Self-inspection trigger condition: The test-run function is used to verify the performance of the drive. Turn the SW5 switch to ON when the power is off. Then turn on the power and in the state of no pulse input, switch the SW5 gear switch from ON gear to OFF gear, and then switch from OFF gear to ON gear after 1 second, that is, start the trial operation function (motor at 1 revolution per second) The speed of the cycle moves forward and backward for one circle).

6. Indicator Function

This product has two red and green LED indicators to show the status:

Features	Indicator status	Description
Motor stop	Flashing green	No pulse input or drive offline
Motor running	Steady green	With pulse input, the motor is running
Motor overcurrent	1green+1red	Motor phase current overcurrent or drive failure
Motor is not connected	1green+2red	The motor is not connected
Overpressure	1green+3red	Power input is greater than 90V
Undervoltage	1green+4red	Power input is less than 18V
Other failures	1green+5red	

4. Power Supply

4.1 Voltage

The chopper drive continuously changes the size and direction of the voltage at the motor winding terminal while working, and at the same time detects the current to obtain an accurate phase current. If you want to ensure high efficiency and low noise at the same time, the drive supply voltage should be at least 5 times the rated phase voltage of the motor (that is, the rated phase current of the motor × phase resistance).

If you need the motor to obtain better high-speed performance, you need to increase the drive supply voltage.

If a regulated power supply is used for power supply, the supply voltage must not exceed 72V. If you use an unregulated power supply, the required voltage must not exceed 53V.

Because the rated current of the unregulated power supply is the full load current; when the load is very light, such as when the motor is not rotating, the actual voltage is as high as 1.4 times the rated voltage of the power supply. If you want the motor to run smoothly and quietly, choose a low voltage.

4.2 Current

The maximum supply current should be the sum of the two-phase currents. Normally, the current you need depends on the motor model, voltage, speed and load conditions. The actual power supply current value is much lower than this maximum current value because the driver uses a switching amplifier to convert high voltage and low current into low voltage and high current. The more the power supply voltage exceeds the motor voltage, the less power supply current is required. When the motor is connected to a 48V power supply, the output current of the power supply is half of the output current of the 24V power supply.

4.3 Regenerative Discharge

When the motor decelerates, it converts the kinetic energy of the load into electrical energy like a generator. Some energy will be consumed by the drive and motor. If your application has a large load running at high speed, considerable kinetic energy will be converted into electrical energy. It is easy to cause drive alarm (overvoltage) or even damage to the drive.

Because this drive has a power supply reverse connection function, it can prevent damage to the drive caused by reverse power connection, so using an external regenerative discharge device does not work.

When your application has a large load running at high speed, please contact the company in advance to shield the anti-reverse connection function and connect an external regenerative discharge device.

5. Motor Connection



Warning: When connecting the motor to the drive, please make sure that the drive power is turned off. Make sure that the unused motor leads are not short-circuited with other objects. When the drive is energized, the motor cannot be disconnected. Do not connect the motor leads to the ground or power supply.

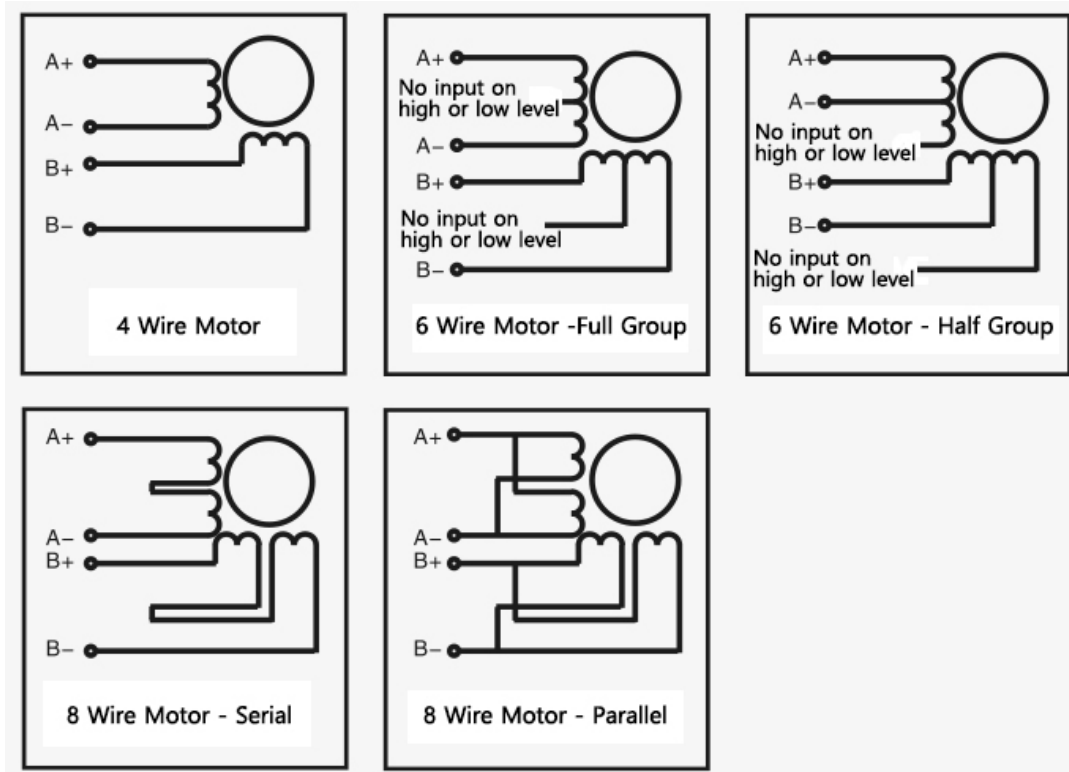

- 1) Four-wire motors can only be connected in one way.
- 2) The six-wire motor can be connected in two ways: full group and half group. In the full group mode, the motor has greater torque when running at low speed, but it cannot run as fast as it is connected to a half group. When the whole group is running, the motor needs to run at less than 30% of the half-group mode current to avoid overheating.
- 3) Eight-wire motors can be connected in two ways: series and parallel. The series connection has a larger torque at low speed, and a smaller torque at high speed. When running in series, the motors need to run at 50% of the current in parallel to avoid overheating.



Notes

- 1) The corresponding colors of different motor leads are different, so please refer to the motor data instructions when using.
- 2) The windings of different phases of the motor cannot be connected to the terminals of the same phase of the driver (A+, A- are one phase, B+, B- are the other phases). If the motor rotation is different from the expected rotation, only exchange A+ and A- The location is fine.
- 3) This driver can only drive two-phase hybrid stepping motors, but not three-phase and five-phase stepping motors.

6. Signal Input

6.1 Pulse Signal : STEP

It can accept 5-24VDC single-ended or differential signals, and the highest voltage can reach 26V. The change from off to on is understood as receiving a valid pulse edge command. For the common anode, the low level is valid (the common cathode is the high level valid), and the driver will drive the motor to run one step according to the corresponding timing. For the normal operation of the driver, the duty cycle of the effective level signal should be below 50%. In order to ensure the reliable response of the pulse signal, the duration of the pulse effective level of the subdivision driver should not be less than 1us. The signal response frequency of the subdivision driver is 500KHz, too high input frequency may get incorrect response.

6.2 Direction Signal : DIR

It can accept 5-24VDC single-ended or differential signals, and the highest voltage can reach 26V. The on and off of the internal optocoupler at this end are interpreted as the two directions of motor operation. The change of the direction signal will change the direction of motor operation. The suspension of this end is equivalent to input high level. It should be noted that the subdivision driver should ensure that the direction signal is established at least 10us ahead of the pulse signal input, so as to avoid the drivers wrong response to the pulse signal. When commutation of the motor, the motor must be decelerated to the starting frequency before commutation. The commutation signal must be changed after the last STEP pulse of the previous direction signal and before the first STEP pulse of the next direction. When no direction change is needed, the direction signal terminal can be left floating.

6.3 Offline Signal : FREE

It can accept 5-24VDC single-ended or differential signals, and the highest voltage can reach 26V. When the built-in optocoupler is turned on, the motor phase current is cut off, and the rotor is in a free state (offline state). When this function is not needed, the offline signal terminal can be left floating.



6.4 Pulse / Direction Input Timing Chart

Input signal waveform and timing (single pulse method)

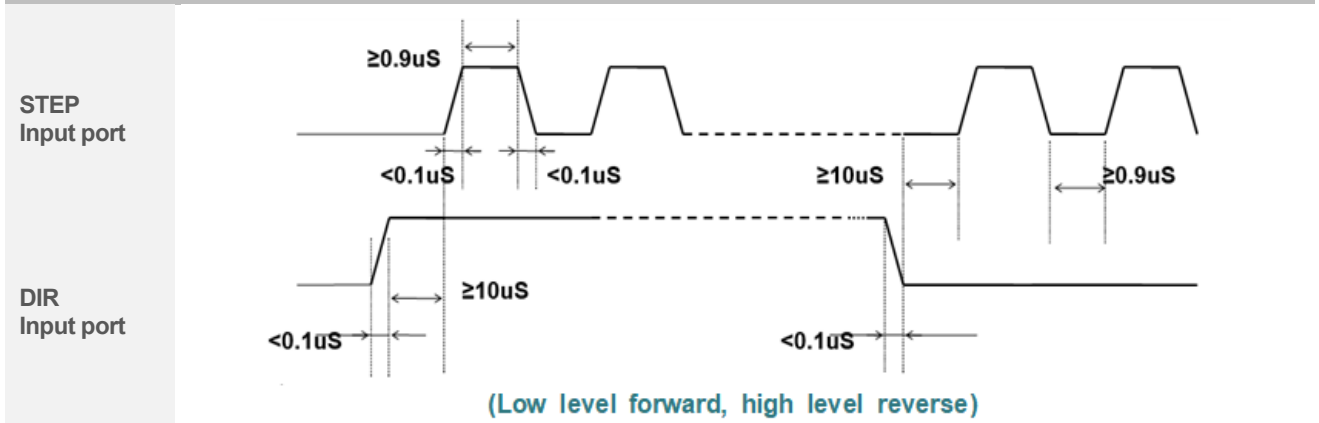

Input signal waveform and timing (double pulse method)

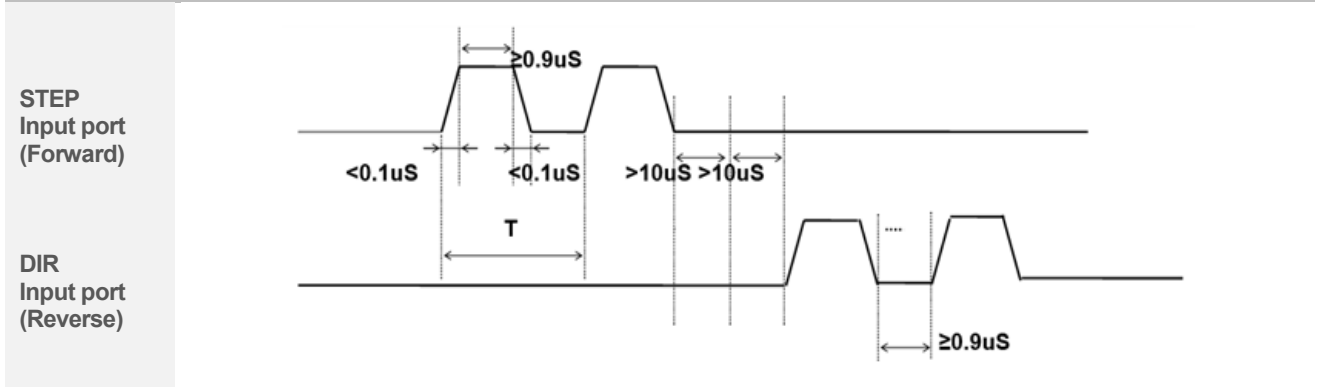

7. Typical Signal Connection

7.1 Differential Connection

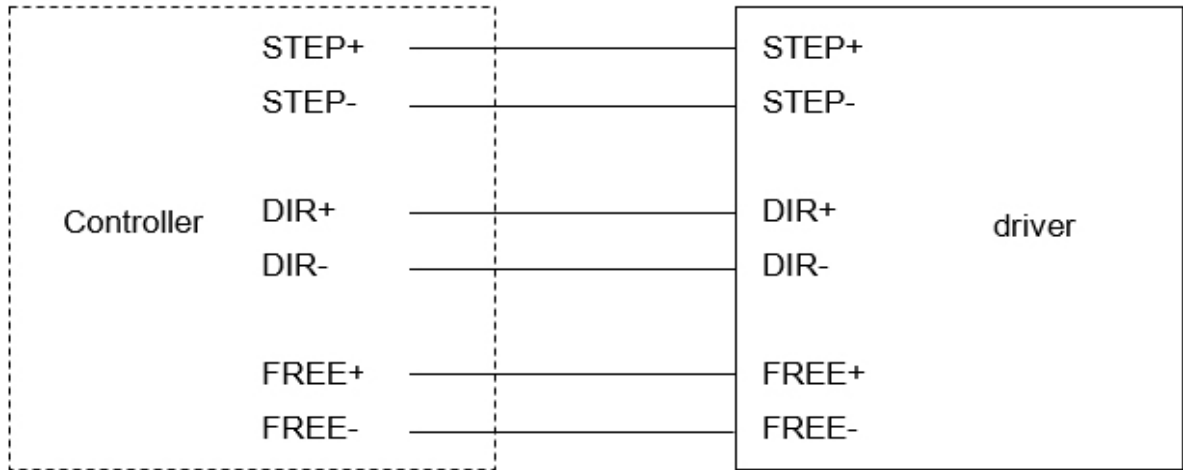

7.2 Common Anode Connection

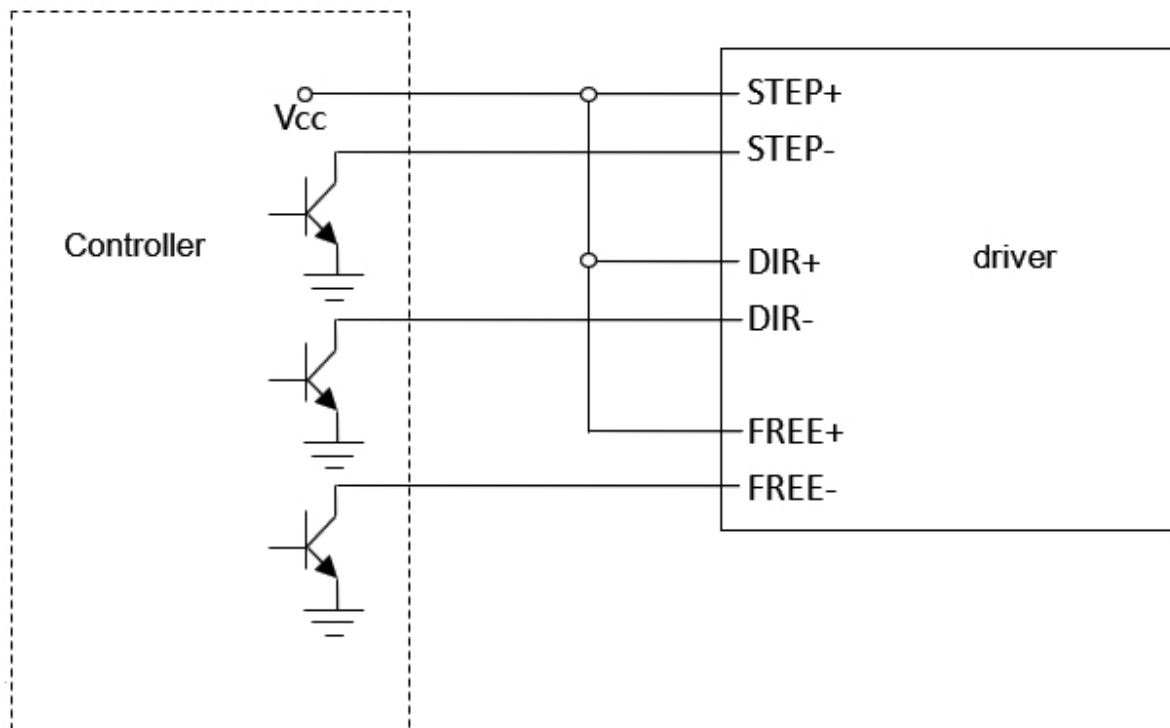



7.3 Common Cathode

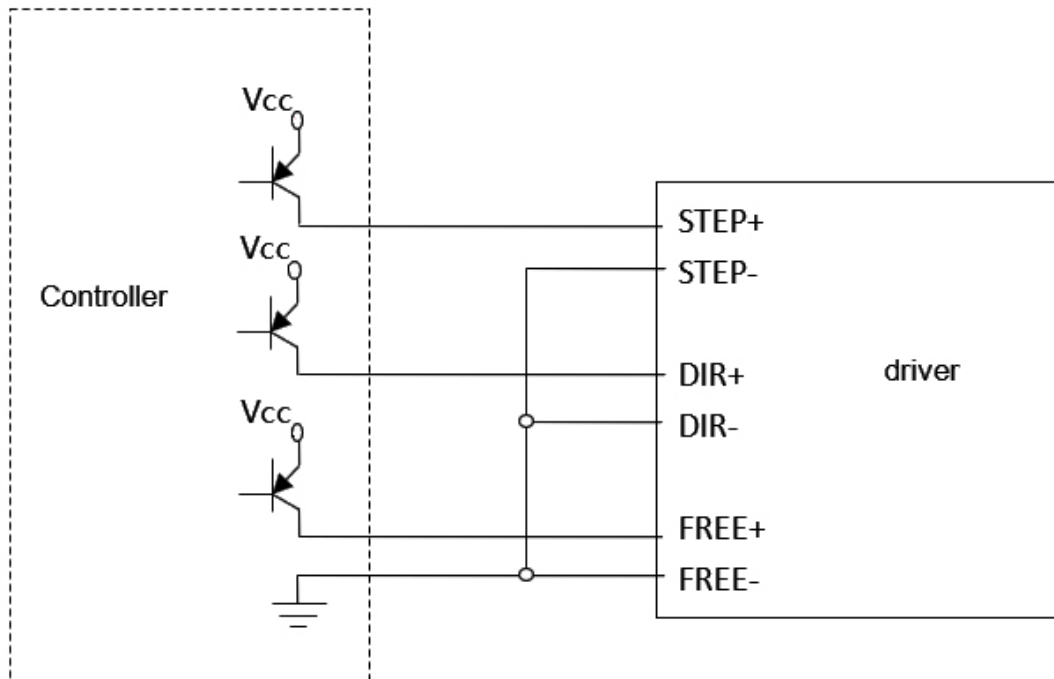

i **Notes** The pulse, direction and offline terminals all have constant current input functions, which can be directly connected to the input signal without external series resistance step-down current-limiting protection. The VCC value is 3.5-26V.

8. Typical Connection of Signal Output



8.1 Relay Connection

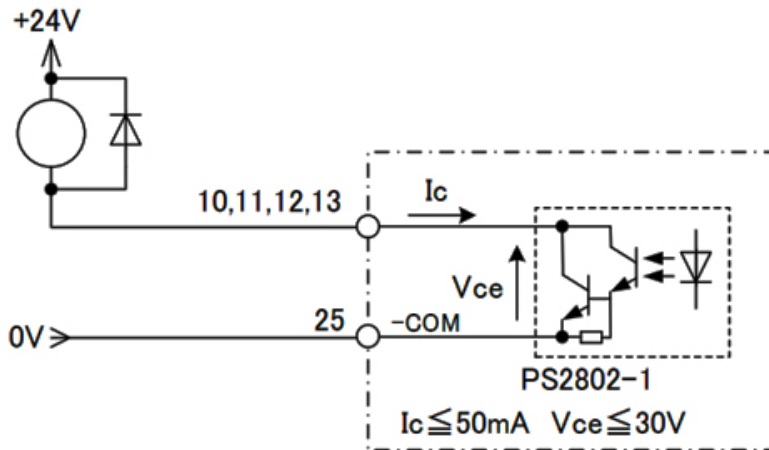

8.2 Optocoupler Connection

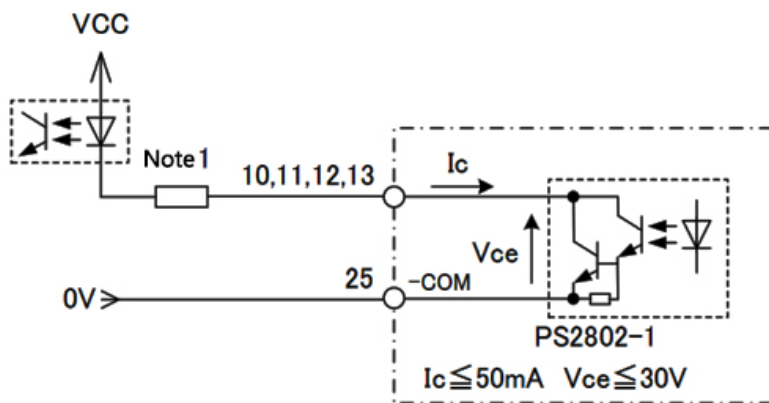

The alarm output is photoelectrically isolated, the maximum withstand voltage is 30VDC, and the maximum saturation current is 50mA.

When the driver is working normally, the output is closed.

When the drive fails, the output is left floating.

9. Wiring Requirements



- 1) In order to prevent the driver from being interfered, it is recommended to use shielded cables for the control signal, and the shielding layer and the ground wire should be short-circuited. Except for special requirements, the shielding wire of the control signal cable should be grounded at one end: one end of the upper computer of the shielded wire is grounded, and the shielded wire One end of the drive is suspended. Only the same point is allowed to be grounded in the same machine. If it is not a real grounding wire, the interference may be serious. At this time, the shielding layer is not connected.
- 2) The pulse and direction signal wires and the motor wires are not allowed to be wrapped side by side. It is better to separate them by at least 10cm, otherwise the motor noise will easily interfere with the pulse direction signals and cause the motor to be inaccurately positioned and the system to be unstable.
- 3) If one power supply supplies multiple drives, parallel connection should be adopted at the power supply, and chain-like connection between one drive and the other is not allowed.
- 4) It is strictly forbidden to unplug and plug the strong current (motor and power supply) terminals of the driver when the power is on. When the charged motor is stopped, there is still a large current flowing through the coil. Unplugging and plugging the strong current (motor and power supply) terminals will cause a huge momentary induced electromotive force and burn out. driver.
- 5) It is strictly forbidden to connect the lead wire to the terminal after tinning, otherwise the terminal may be damaged by overheating due to the increase of the contact resistance.
- 6) The wire end of the wiring should not be exposed outside the terminal to prevent accidental short circuit and damage to the drive.

10. Installation Size (unit : mm)

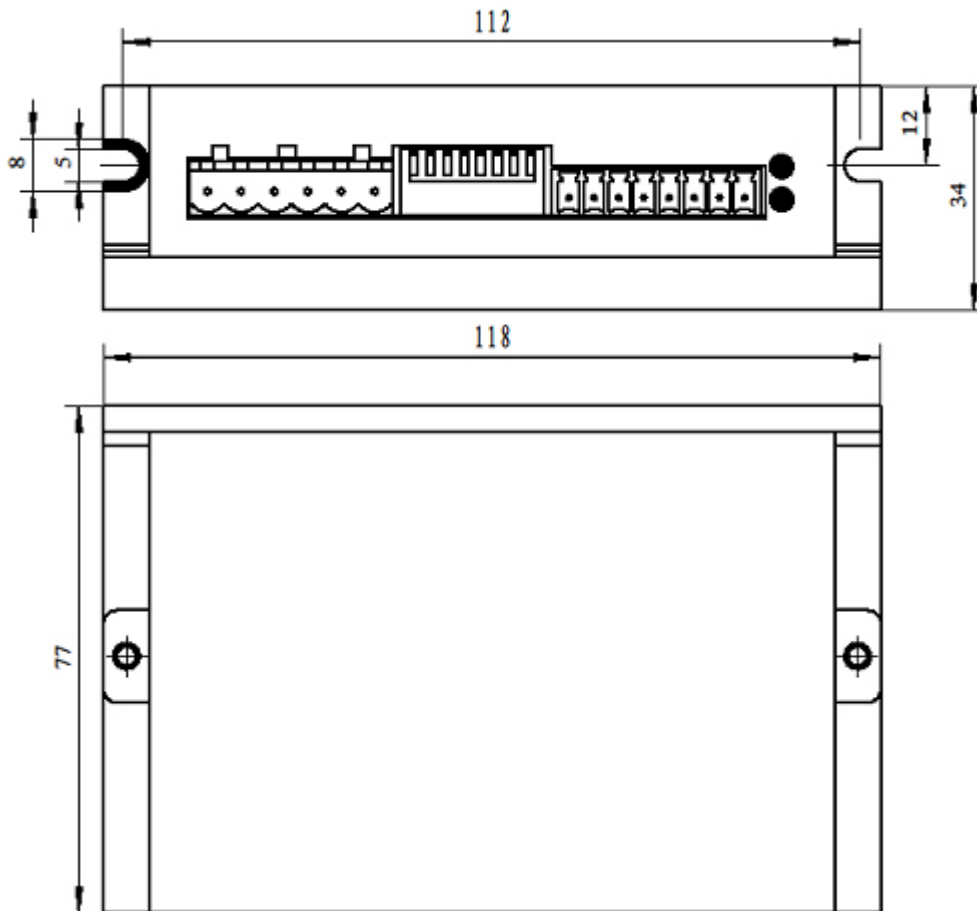

Drive installation

Use the narrow side to install, and use M4 screws to install through the holes on both sides. The power device of the driver will generate heat. If it is continuously working under the condition of high input voltage and high power, the effective heat dissipation area should be enlarged or forced cooling.

Do not use it in places where there is no air circulation or where the ambient temperature exceeds 40°C; do not install the drive in a humid place or a place with metal shavings.

 +86-0519-8517 7825

 +86-0519-8517 7807

 Building 1#,355 Longjin Road, Changzhou Economic Development Zone, Jiangsu, China

 www.dingsmotion.com

International Customer

Person in Charge :

Daniel Jang

daniel@dingsmotion.com

Building 1#,355 Longjin Road,
Changzhou Economic Development
Zone, Jiangsu, China

+86-519-85177826, 85177827

North America Customer

Person in Charge :

Nicolas Ha

nha@dingsmotionusa.com

355 COCHRANE MORGAN CIRCLE
HILL, CA 95037

+1-408-472-1971

China Customer

Person in Charge :

Sweet Shi

slq@dingsmotion.com

Building 1#,355 Longjin Road,
Changzhou Economic Development
Zone, Jiangsu, China

+86-519-85177826, 85177827